

Installation, Operation & Maintenance Instructions

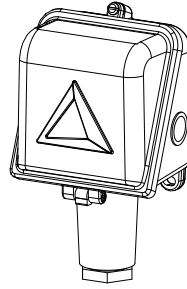

Sentry Series

Models P0* (Pressure Switches)

Models D0* (Differential Pressure Switches)

Models T0* (Temperature Switches)

General

The unit is manufactured, checked and supplied in accordance with our published specification, and when installed and used in normal or prescribed applications, with the lid in place and within the parameters set for mechanical and electrical performance, will not cause danger or hazard to life or limb.



THE USERS ATTENTION IS DRAWN TO THE FACT THAT, WHEN THE UNIT IS 'LIVE' WITH RESPECT TO ELECTRICAL OR PRESSURE SUPPLIES, A HAZARD MAY EXIST IF THE UNIT IS OPENED OR DISMANTLED.



UNITS MUST BE SELECTED AND INSTALLED BY SUITABLY TRAINED AND QUALIFIED PERSONNEL IN ACCORDANCE WITH APPROPRIATE CODES OF PRACTICE SO THAT THE POSSIBILITY OF FAILURE RESULTING IN INJURY OR DAMAGE CAUSED BY MISUSE OR MISAPPLICATION IS AVOIDED.

Operating principles

Pressure Switch models P02 & P03 and Differential Pressure Switch models D02 & D03 are diaphragm operated switches.

These diaphragms generate a force proportional to the applied pressure and are balanced by a user adjustable control spring. When the force exceeds that created by the control spring, the diaphragm moves causing a push rod to actuate a snap-acting micro-switch.

Temperature models T02 & T03 work in the same way as the Pressure models with the exception that the applied pressure comes from the expansion of a vapour enclosed in either a rigid stem or semi-rigid thermal system.

INSTALLATION

Mounting (All models)

The instruments are designed to be mounted vertically with the process connection underneath. However, mounting up to 45° from the vertical in any plane is acceptable, although a small calibration shift may

occur. They can be mounted either direct to process, or to a wall or panel using the mounting holes provided. Select the mounting point so as to avoid excessive shock, vibration or temperature fluctuation. Instruments should be mounted to avoid excessive heat transfer from the process lines or adjacent plant. To avoid undue stresses being imparted to the instrument when wall/panel mounted, it is recommended that a short length of flexible line be installed between the instrument and process line. If sudden changes of pressure (pulsations) are likely then we recommend that snubbers are fitted between the process line and instrument. Use a spanner to support the process connection when fitting the instrument.



CHECK THE CONNECTION THREAD SIZE AND SPECIFICATION ON THE UNIT TO AVOID MIS-MATCHING WITH THE PROCESS CONNECTION ADAPTOR. SEE DIGIT 11 OF PRODUCT CODE.

Mounting (T02 - Rigid Stem)

Assemble the unit either directly or via a thermowell, using the spanner facility provided and ensuring that:

- the sensing bulb is fully immersed in the process temperature
- the sensing bulb does not bottom out in the thermowell which could cause damage

Mounting (T03 - Capillary system)

Mount the sensing bulb so that the capillary end is above the bulb and the bulb is level with, or no more than 250mm below the base of the instrument. The stem is fitted with a sliding compression gland to accommodate different thermowells.

Wiring



DISCONNECT ALL SUPPLY CIRCUITS BEFORE WIRING



WIRE IN ACCORDANCE WITH LOCAL AND NATIONAL CODES. USE CABLES NO LARGER THAN 2.5 MM² (14 AWG)



DO NOT EXCEED ELECTRICAL RATINGS STATED IN LITERATURE AND ON NAMEPLATES.

Wiring (continued...)

Undo the single lid retaining screw and allow the hinged lid to rest in an open position. Be careful not to apply excessive pressure on the opened lid to avoid damage to the hinge.



IF HINGE IS DAMAGED, INGRESS PROTECTION LEVEL COULD BE COMPROMISED.

A single M20 or ½"NPT electrical entry is provided, into which a cable gland can be assembled. Select a suitable cable gland which will maintain the IP rating of the instrument.

The three switch terminals are clearly marked "NORMALLY CLOSED", "NORMALLY OPEN" and "COMMON".

For products supplied with terminal blocks, the following diagram can be used as a guide for wiring.

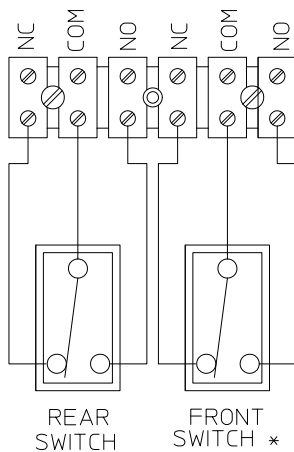

NC = NORMALLY CLOSED
COM = COMMON
NO = NORMALLY OPEN

* ONLY PRESENT ON DPDT SWITCH MODES
(SEE TABLE 6)

Insert bare wires fully into the terminal block and tighten securely. Keep wiring tails to a minimum and check that wires do not interfere with the operating mechanism. Use the earthing / grounding points provided.



BEFORE CLOSING THE LID:

- ENSURE WIRE IS CLEAR OF ALL MOVING PARTS.
- CHECK THAT THE GASKET IS SEATED CORRECTLY AND IN GOOD CONDITION
- ENSURE THAT WIRES DO NOT TOUCH THE LID AS IT IS CLOSED

Close the lid, being careful not to trap any wires in doing so. Tighten the lid locking screw until the lug on the top of the lid makes contact with the enclosure lug.

OPERATION

Adjustments

Pressure and Temperature Switches are supplied calibrated at the midpoint of their range and to a falling pressure or temperature unless otherwise specified.

To re-calibrate:

1. Isolate the instrument from the process and power.
2. Loosen lid lock screw and open the lid.
3. Slacken the set point lock screw.
4. Using a suitable spanner, rotate the range adjuster clockwise to increase the set point and counter-clockwise to decrease the set point.
5. Tighten the set point lock screw.
6. Close the instrument lid and tighten lid lock screw

Note: For accurate setting of Pressure and Differential Pressure models, a suitable pressure gauge must be used in conjunction with the above procedure. Do not attempt to set the switch outside the scale limits. For Temperature models a suitable calibrated temperature source should be used.

Though the unit may be set anywhere within its range, for optimum performance, it is good practice to have a set point value between 25% and 75% of span.

The striker screw and lock nut are factory set and should not be adjusted. Should these parts be accidentally loosened, please contact Delta for assistance.

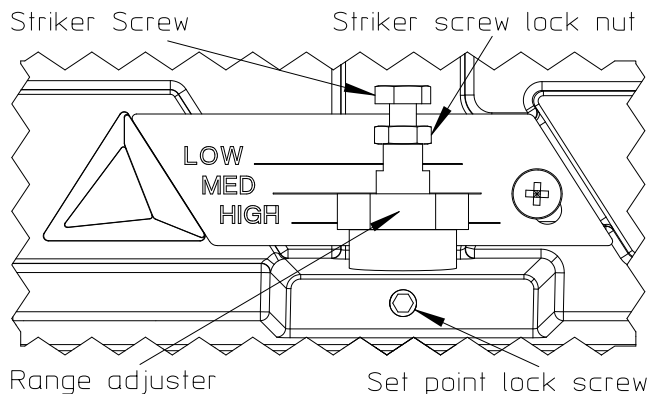

MAINTENANCE

Inspections should be carried out at quarterly to yearly intervals depending upon operating conditions. Isolate the unit from process and power and remove the lid. Check all terminals for tightness. Check that cable tails are not fouled or chafed. Check for internal condensation. Check that the gasket is seated properly in the lid recess and is not worn.

It is recommended that instruments used to provide an alarm are operated periodically to ensure they are functioning correctly.

If further maintenance is required seek advice from DELTA CONTROLS before attempting repair or replacement of parts.

DIMENSIONS

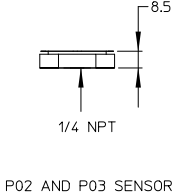
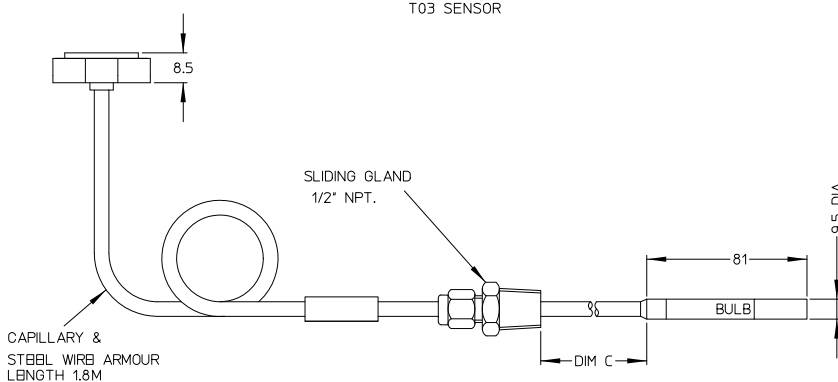
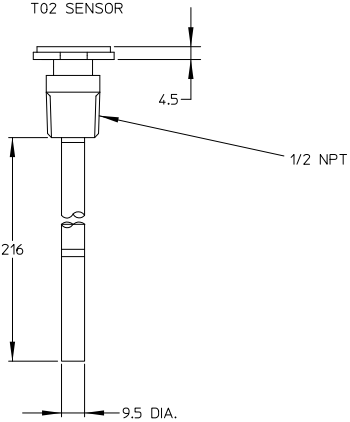
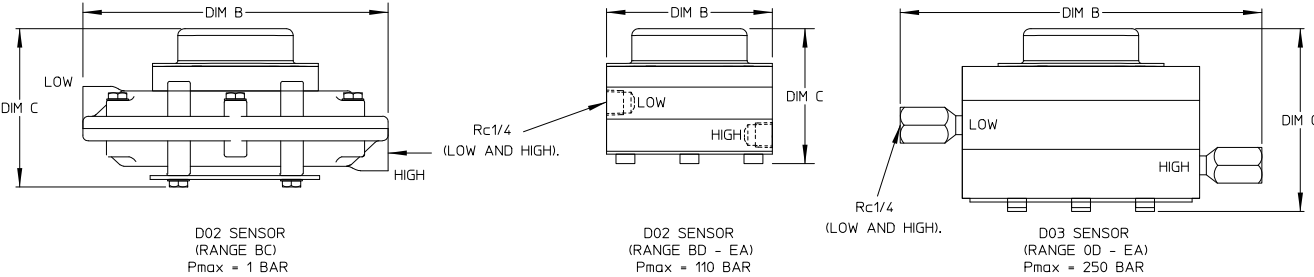
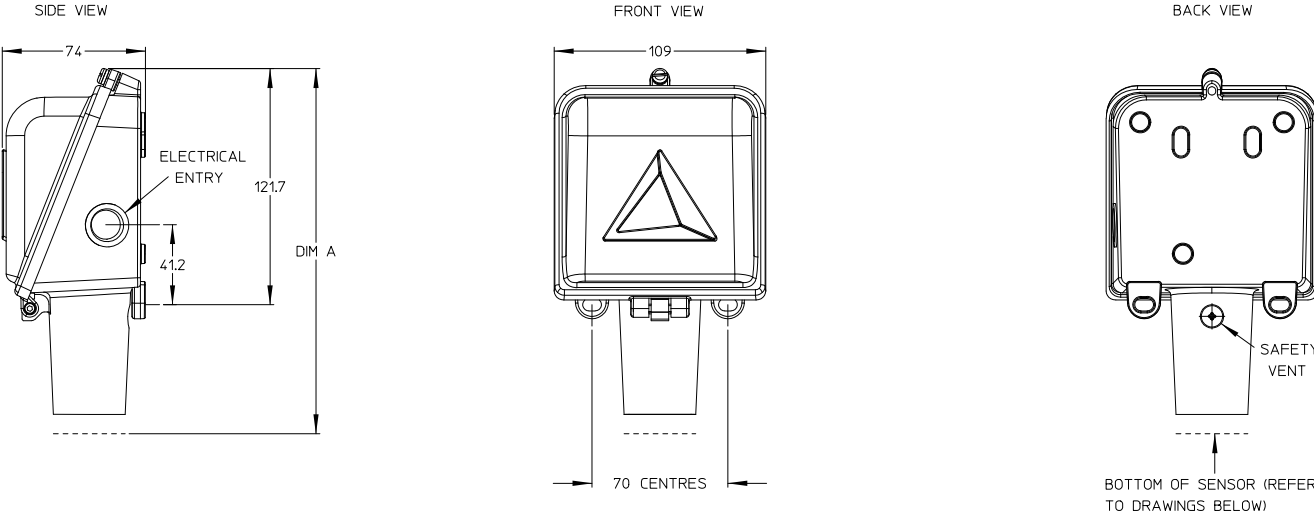

| Model | Range | DIM A | DIM B | DIM C |
|-----------|---------------------|-------|-------|-------|
| P02 / P03 | ALL | 187 | - | - |
| D02 | BC | 263 | 162 | 84 |
| | BD - CE | 251 | 114 | 72 |
| | DC - EA | 250 | 88 | 72 |
| D03 | OD - OE | 276 | 192 | 97 |
| | DC - EA | 275 | 166 | 97 |
| Model | Thermal System Code | DIM A | DIM B | DIM C |
| T02 | R | 183 | - | - |
| T03 | N | 187 | - | 250 |
| | P | 187 | - | 500 |

Delta Controls Limited

Island Farm Avenue, West Molesey, Surrey KT8 2UZ, UK.

T+44 (0)20 8939 3500 **F**+44 (0)20 8783 1163 **E** sales@delta-controls.com **W** www.delta-controls.com